

# Bandpass Receiving Loop Antennas

Jim Moritz, M0BMU

I have been using these loop antennas for about a year now, for 136kHz and other frequencies in the LF range; they are a departure from the traditional receiving loop technique, and seem to work very well, so I thought I would write them up.

The traditional tuned loop antenna is a high Q tuned circuit, buffered with a high impedance preamp. This gives a useful pre-selector action along with directional nulls and small size. It also has drawbacks; even for use over 135.7kHz – 137.8kHz, it is necessary to peak the tuning, since the bandwidth is usually less than 1kHz. This requires some sort of remote tuning. Remote tuning can be avoided by loading the loop to reduce the Q, but this also reduces the output signal level and signal-to noise ratio too, meaning a bigger loop is needed. Also, the out-of-band selectivity is degraded. At my location, the field strength due to the local MF broadcast stations is of the order of 10s of volts per metre, and the selectivity provided by the loop is not good enough to prevent the usual FET based preamps from overloading. So it would be nice to increase the bandwidth without adding resistive loading, and at the same time improve the attenuation outside the passband.

If one is designing a bandpass filter, a wide passband with sharp cut-off outside the passband (ie. a good shape factor) is achieved by coupling two or more tuned circuits together. The tuned loop is essentially a tuned circuit with the magnetic flux component of the signal coupling to the loop. It can be made into a bandpass filter by coupling it to the receiver via additional tuned circuits. In principle, you could use as many tuned circuits as you like, but more tuned circuits means increased losses and complexity, and in practice a “2 pole” filter using the loop itself and a single additional resonant circuit seems adequate for most purposes. One can use coupled-resonator or ladder filter design techniques, or the techniques that were used for the old valve-type double tuned IF transformers, to get a flat-topped or double-humped (Butterworth or Chebyshev) bandpass response. The bandwidth at the –3dB points is wider than the bandwidth of either tuned circuit by itself, and the attenuation increases more rapidly beyond the –3dB points than would a single tuned circuit. This is achieved without adding resistive loading (in practice there will be some small additional losses due to the extra components), so the SNR remains much the same as for the singly-tuned loop.

## 1m<sup>2</sup> Bandpass Loop

The first design started from a 1m<sup>2</sup> loop with 10 turns of wire. This had an inductance of 380μH and a Q of about 170 at 137kHz. After some trial and error, coupling it to a second tuned circuit with a loaded Q of 30, with a coupling coefficient of about  $7.4 \times 10^{-4}$  gave a slightly double humped response with a bandwidth of about 4kHz, flat within +/-1dB, centred on 137kHz (see fig. 6). The response is down –40dB at about 115k and 160k, so good filtering of LF broadcast stations and Loran is provided. The circuit is shown in figure 1:

Loop - 1m<sup>2</sup>; 1m x 1m square.  
2 windings of 5t, 1mm<sup>2</sup>, 32/0.2  
PVC insulated wire

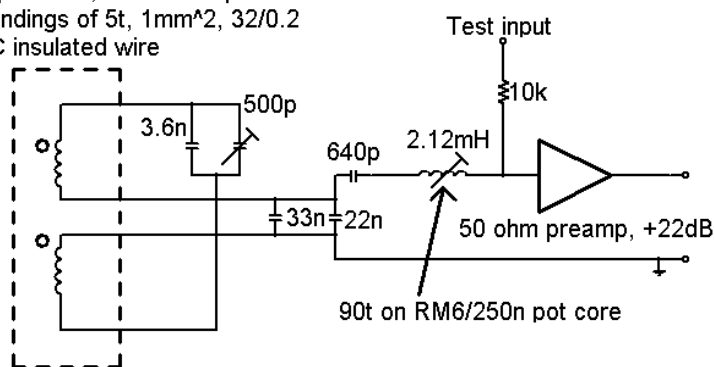

Figure 1 – 1m<sup>2</sup> bandpass loop

In one version, the loop wires were supported by a cross-shaped wooden frame, and taped together in a bundle. In another version, the loop wires were taped together, and enclosed in 20mm PVC round cable trunking, with wooden supports. The wire used was 1mm<sup>2</sup> “tri-rated switchgear cable”, which has quite thick PVC insulation (and for some reason is quite cheap!). If different types of wire were used, it would probably be necessary to alter the tuning capacitance to allow for minor changes in stray capacitance and inductance of the loop; alterations that substantially altered the Q of the loop would require re-design of the component values. The loop is effectively series-tuned by the 3.6nF+500pF, and the output is taken from the centre of the winding, rather than one end, so that it is approximately balanced w.r.t. ground. The secondary tuned circuit consists of the 640pF/2.12mH, and the coupling is provided by the 22nF+33nF capacitors. The 50Ω preamp input impedance defines the loaded Q of the secondary tuned circuit. The capacitors should be polystyrene, polypropylene, mica or other low-loss types.

To tune the antenna, Dishal's method can be used. Connect a 137kHz signal source to the "test input" point, and disconnect one end of the loop winding. Monitor the preamp output signal. Tune the 2.12mH inductor for a sharp null in output. Reconnect the loop, and tune the 500pF trimmer for a peak in output. Then disconnect the generator from the test input. You can check the desired response has been achieved by connecting a generator to a small single turn loop placed near the antenna, and sweeping the frequency across the band. If the response is slightly asymmetrical, experimentally adjust the trimmer in tiny amounts for the best result.

### 2m x 2m Bandpass Loop

The second antenna uses the same principle with a larger, single turn loop to achieve a wider bandwidth. The loop is a self-supporting square made from 2m lengths of 15mm copper water pipe, joined together by elbow compression fittings. The inductance of this is about 7.9uH, and the Q is about 220 at 137kHz. A somewhat different circuit is used; this is a singly-terminated ladder design with one series and one parallel tuned circuit. This gives less design flexibility than the coupled resonator circuit, but the bandwidth came out right for my purposes. It gives a flat-topped Butterworth response that is 1dB down at 18kHz bandwidth, -3dB at 26kHz BW, and -20dB at 86kHz BW (see fig. 6). The circuit is shown in figure 2.

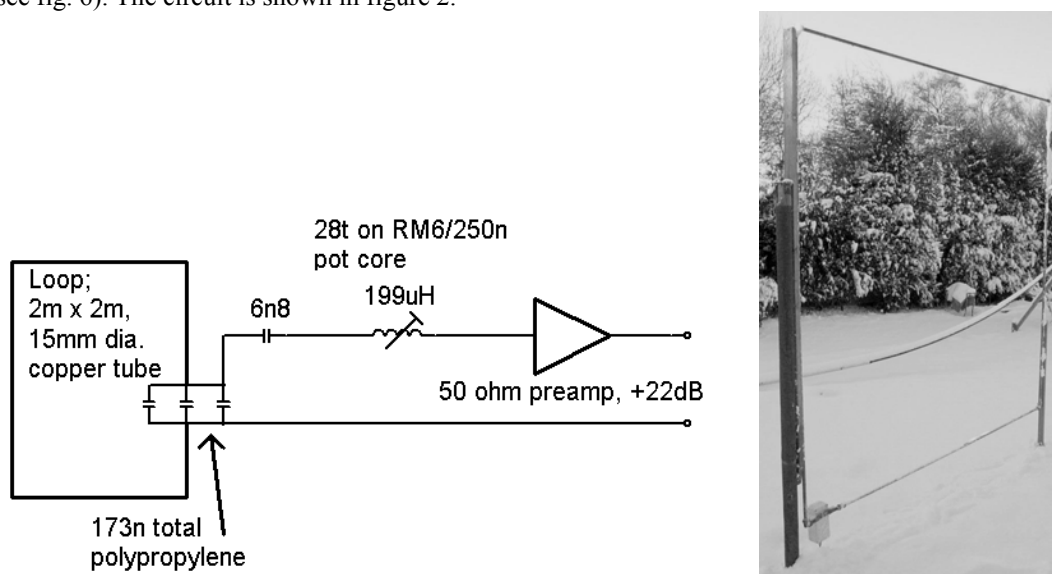

Figure 2 – 2m x 2m Bandpass Loop

The tuning capacitance required to resonate the loop is a rather large 173nF, and I used several smaller value polypropylene capacitors in parallel connected directly across the loop terminals. It is not really practical to provide a trimmer with this large a value, but the tuning is much less critical than with the smaller bandwidth antenna, so provided the resonant frequency is within about +/-1kHz or so of 137kHz, the response will not be seriously affected. The loop and the secondary tuned circuit were separately adjusted to resonance at 137kHz before being connected together, and this was found to be quite sufficient.

### 2m x 2m Wide band loop

I wanted to make a loop antenna that could be used over the LF/VLF range below 150kHz, for direction finding and making field strength measurements in conjunction with a selective level meter. One way of doing this is to use a single turn, un-tuned loop, which has a predictable relationship between field strength and output voltage. But a small 1m<sup>2</sup> un-tuned loop gives rather poor sensitivity, and, at my location, a larger loop results in receiver overload by the nearby broadcast stations. It would be possible to put a preselector between the loop and the receiver, but this would be another "unknown" factor in the amplitude calibration, plus there would be the nuisance of having to re-tune the preselector every time the receiver was set to a different frequency.

After experience with the bandpass loops, I decided it should be possible in a similar way to incorporate the loop inductance as part of a low-pass filter – this resulted in the circuit of figure 3. Again, a 2m x 2m loop of copper water pipe is used. This connects to a 1:2 step-up transformer, which doubles the signal voltage, and also increases the apparent inductance of the loop by a factor of 4 (the same effect as having a 2 turn loop, really). The other capacitors and inductors form a low-pass filter that is 1dB down at 230kHz, -20dB at 400kHz, and -40dB at 700kHz, giving adequate attenuation of the medium wave signals. The component values are designed for 75Ω load impedance, since this is the standard input impedance of most selective level meters (it also suits cheap "satellite TV" coax) You might think the transformer would limit the lower frequency of the loop, but although the impedance of the transformer windings falls with decreasing frequency, so does the source impedance of the loop,

and so the lower frequency is only really limited by the receiver. The end result is an antenna that behaves like an  $8\text{m}^2$  un-tuned loop at frequencies up to 200kHz, and provides attenuation above that.

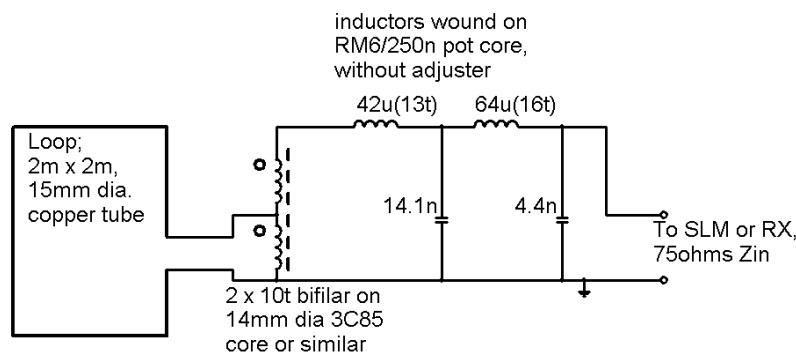

**Figure 3 – Wide band loop**

Since the filter network is very low Q, no tuning is required. The output voltage of an un-tuned loop is:

$$V = 2.1 \times 10^{-8} \times fNAE$$

Where f is frequency in Hz,  
 N number of turns  
 A loop area in m<sup>2</sup>  
 E electric field strength, V/m

After its loading effect is taken into account, the step-up transformer increases the output by a factor of 1.8. This makes the “antenna factor” (dB ratio of output voltage to field strength):

$$\frac{V}{E} = 20 \log_{10}(1.59 \times 10^{-4} \times f) \quad (f \text{ in kHz})$$

For example, at 137kHz, the antenna factor is  $-33.2\text{dB}$ . If you measure the signal voltage at the loop output, then add 33.2dB, you get the field strength. The antenna factor is proportional to frequency (see figure 6), so the antenna gets less sensitive as the frequency decreases. However, since the atmospheric noise level increases at lower frequencies, this is not a limitation in practice.

### Preamplifier

The output of these antennas is quite small; the antenna factor for the wide band loop is  $-33.2\text{dB}$ , for the  $1\text{m}^2$  and  $2\text{m} \times 2\text{m}$  tuned loops it is around  $-25\text{dB}$  and  $-21\text{dB}$  respectively. On 136kHz, this puts the band noise at about  $0.1\mu\text{V}$  or less in 300Hz BW for the tuned loops on a quiet day, so a preamp is needed, unless you have a very sensitive receiver. The pre-amp in figure 4 is the same as used in my “lazy loop” article (see G3YXM’s web site:- <http://www.wireless.org.uk/lazy.htm>). It has quite low noise level; less than  $0.02\mu\text{V}$  with  $50\Omega$  source impedance. Due to the use of negative feedback and a fairly high bias current, it also has good linearity, and will overload most receivers before generating significant distortion products. The input impedance is determined by feedback and is close to  $50\Omega$ . The output impedance is roughly that of the  $22\Omega$  series resistor, which ensures stability with capacitive loads. With  $50\Omega$  load, gain is about 22dB.

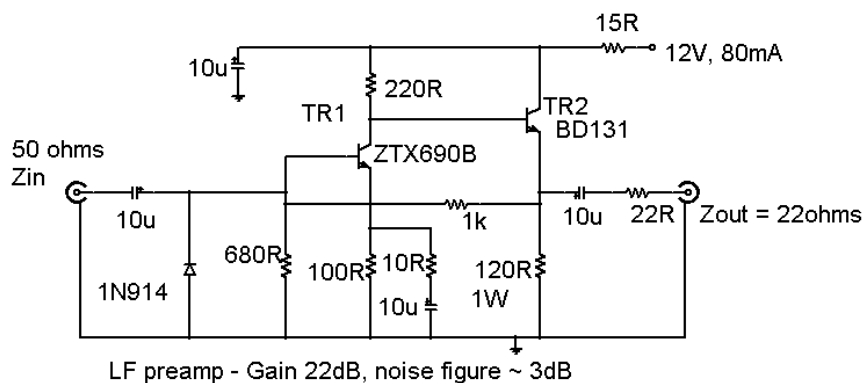

**Figure 4 – Pre-amp**

The ZTX690B is the best device I have found so far for this circuit; if you want to use something else, look for a small power device with a very high  $\beta$  at high bias current, and a  $f_T$  of at least 50MHz – the ZTX 690B has minimum  $\beta$  of 400 at 1A. The ZTX650 worked well too. A 2N3019 in the junk box was only slightly worse. Devices like the 2N2222 will work, but will generate a couple of dB higher noise level. TR2 is less critical; it should have  $\beta > 50$ ,  $f_T > 50$ MHz, and be able to dissipate about 1W. A 2N3053 and a BFY51 worked fine. The capacitors were all 10 $\mu$ F tantalum – smaller values can be used if VLF coverage is not required. For the tuned loop designs, I built the pre-amps into the antennas themselves; although not essential, this ensures that the loop circuit is always connected to the correct load impedance, and also reduces the effect of any noise picked up by the cable. I fed the DC supply down the coax using the capacitor/choke arrangement shown in figure 5

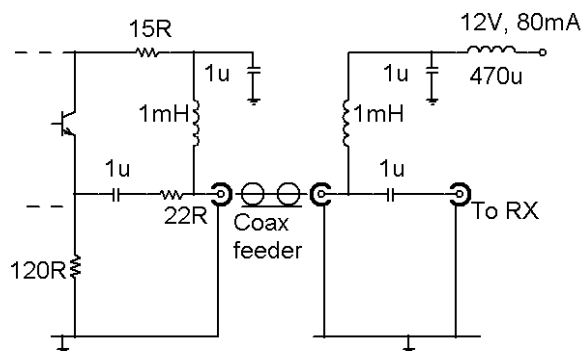

Figure 5 – Remote DC feed to preamp

To protect the pre-amps while transmitting, I initially used a relay with a normally closed contact connected across the loop, energised from the pre-amp supply. The T/R switching switched off the 12V pre-amp supply while on transmit, causing the relay to short the loop out. But it became apparent that this was not necessary, after the inevitable accidents! Even running 1.2kW of transmitter power at 136k to a long wire antenna directly above the receiving loop only induces a few volts pk-pk RF at the pre-amp input, which does not cause any harm.

### The loops in use

I have used the two tuned loop designs extensively for 136kHz operation. When used in conjunction with the pre-amp also described, and connected to a receiver with respectable sensitivity (eg. RA1792; 10dB SNR in 300Hz BW with 0.1 $\mu$ V input p.d.), either design gives a noise floor that is well below the external band noise, even under the quietest band conditions. No problems have been found due to intermods from either the local broadcast stations, or the various strong LF signals there are in SE England. These loops also work quite well with my IC718 transceiver, which receives down to 30kHz. Like most amateur rigs, it has poor sensitivity at LF (about 1 $\mu$ V for 10dB SNR in 250Hz BW). In spite of this, sensitivity with the loops is OK, except under very quiet band conditions. A further 10dB preamp gain would probably be useful with this rig.

The 1m<sup>2</sup> loop has been used both for 2 way operating, and for various portable receiving purposes, such as trying to track down noise sources. I used a pair of the 2m x 2m tuned loops with a phasing network to cancel out some local noise sources that were causing me problems at one point, which was quite successful. The relatively wide bandwidth means adjusting the phase is less critical, and the slightly higher output allows for some losses in the phasing network. I also use two loops at right angles; one oriented to null out the Loran sidebands from Lessay, and the other for receiving signals that are in the null of the first antenna. This gives close to optimum conditions for receiving almost any 136kHz station just by switching between the two antennas. Most of my LF operating over the past year or so has used this set up.

The wideband loop has been very handy for measuring signal strengths, and also direction finding. For field strength measurements, I have mostly used it with a W&G SPM19 selective level meter. Comparing the measurements obtained using this antenna with the formula above, and measurements made around 73kHz and 136kHz using calibrated ferrite rod antenna gives results that agree to within a couple of dB. Because of the larger size, weaker signals can be measured than when using the ferrite rod. When used in conjunction with the 50 $\Omega$  pre-amp, sensitivity is somewhat down compared to the bandpass designs. However, external atmospheric noise is still usually the limiting factor throughout the LF/VLF range from 10kHz – 200kHz. It is therefore a very useful general purpose low frequency antenna. It does require a receiver with good dynamic range, since most of the LF broadcast and utility signals are present at high levels at the receiver input – I imagine this might be a problem in a location near high power LF stations, such as Rugby or Droitwich. I am shortly going to mount the wideband loop on a rotator, to save frequent trips down the garden for D/F purposes!

It is very important to find a good location for an LF loop antenna; moving it a few metres can radically alter the noise level picked up from mains wiring, which seems to be the main source of local noise. Generally, this means putting the loop as far away from buildings and wiring as possible. An indoor loop antenna will almost certainly be

disappointing! If you do have a noise problem, it is quite often possible to find a position where the noise can be nulled by the directional loop, whilst still picking up signals from useful directions. The direction for nulling the noise can change over quite short distances; experimentation is in order. To connect the loop to the receiver, I found that “satellite TV” coax (similar to the normal cheap and nasty TV coax, but with a metal foil under the braid for improved shielding) was cheap and gave good results, although finding decent weatherproof connectors are a problem for this type of cable. I found that it was unnecessary to provide additional grounding at the antenna end of the cable, but it might make a difference to noise pick-up in some circumstances. I have not attempted to make these designs fully balanced – it is supposed that this improves noise rejection, but in practice I have not found any difference.

These designs (especially the single turn loops) are easy to weatherproof, and because of their low L, high C nature do not seem to be significantly de-tuned by rain and ice.

To illustrate the frequency response of the three loops described, I simulated them using Pspice, as shown in figure 6. The input signal was set to be equivalent to a field strength of 1V/m, and the vertical axis is in dB relative to 1V. This simulation does not include the preamp gain. Note the frequency axis is different for the wideband loop.

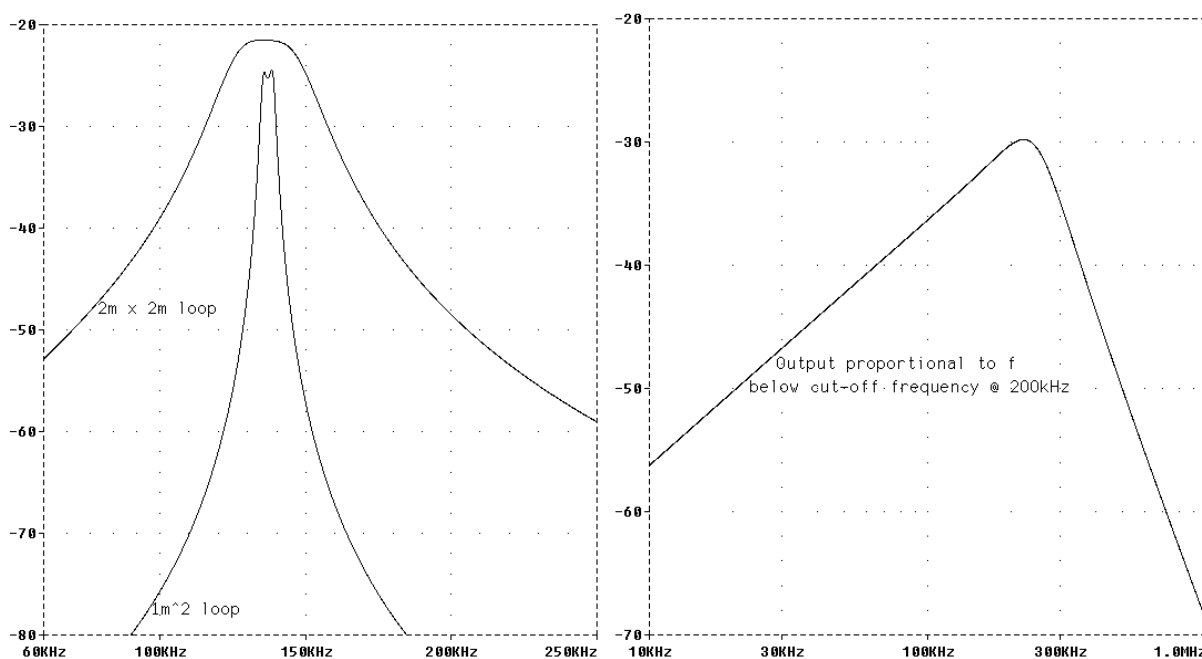

**Figure 6 – Simulated frequency response of the loop antennas**

I am surprised the idea of making a loop antenna an integral part of a bandpass filter does not seem to have been used more widely (although I am pursuing some vague references to a ferrite rod Loran receiving antenna using this idea). I would be interested to hear if there have been any similar designs. I also tried a similar design for 1.8 – 2.0 MHz with good results. It should be quite easy to design bandpass loop antennas to cover the whole MF broadcast band without re-tuning, and many similar applications. It is also possible to apply much the same principle to an E-field antenna.

©J.R. Moritz, M0BMU  
31<sup>st</sup> January 2003

E-mail: [j.r.moritz@herts.ac.uk](mailto:j.r.moritz@herts.ac.uk)